

IDEAL
DOOR
COMPONENTS

Product CATALOG



Contact / chick@chicksdoorplugs.com
800.666.7305
503.657.7300 - fax
503.201.7546 - cell

chicksdoorplugs.com

IDEAL DOOR COMPONENTS

Manufacturer of door and window packaging protection components. All of our products are proudly manufactured in the USA using quality-tested recycled materials!





Ideal Door Components, Inc. is a third generation, family-owned and Oregon-based corporation. Chick Sales invented the original patented Door Plug in 1990. Our products are proudly manufactured in the USA using recycled materials.

We strive for our quality products to be a valuable contribution not only to the prehung door manufacturers of America, but internationally as well.

We welcome each of you as a valued part of our business and are grateful to our customers, distributors and sales representatives for the support and opportunities which have contributed to our continued growth.

Sincerely,
Your Friends at Ideal Door Components, Inc.



800.666.7305
503.657.7300 - fax
503.201.7546 - cell
chicksdoorplugs.com

Chick's® STANDARD (1PDP-A) and ECONOMY (1PDP-E) Door Plugs



- Eliminates damaged doors and jambs caused by failures of the duplex nail or other devices during assembly and/or shipping.
- Installs in seconds. Raised cross-tee feature on the bolt assures faster and easier assembly in the shop and disassembly in the field.
- Telegraphs misalignment of strike prep and edge bore **before** the door unit leaves the shop.
- Saves time of predrilling hardwood or pre-finished jambs. Acts as an alignment guide for the installer while hanging the door unit.
- Saves money on costly call backs on damaged door complaints in the field or in the customers' warehouse.
- Acts as an alignment guide for the installer while hanging the door unit.
- Performs as a latch bolt on 2-3/8" backsets on exterior door units during construction to keep entry door or swinging patio door closed without use of wedges or other devices.

*Made in
America!*

Conclusion: It's simply the best way to ship and handle pre-hung door units!

SPECIAL NOTE TO THE INSTALLER: Remove bolt from back side of jamb before installation of the unit. Plug portion may remain in the door and jamb while setting the door unit in rough opening. Plug may engage or disengage jamb as needed while aligning door unit.

Installation Instructions

Standard Door Plug Requirement

Insert Standard Door Plug through face bore into 1" edge bore. Slide Door Plug into edge bore until secured by cinch ring and Door Plug end cap.

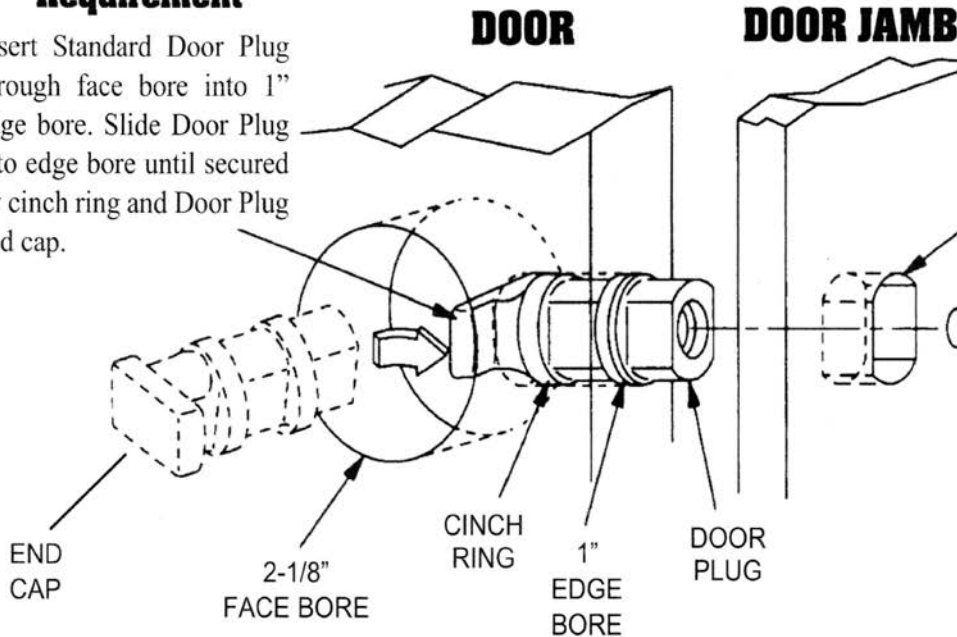

Bolt Requirement

3/4" x 1" rectangular route or 1" diameter bore required. Route completely through door jamb and insert bolt from backside of door jamb into Door Plug.

Bolt and washer have multi-point grip and anti-vibration features for added security as well as faster and easier installation.

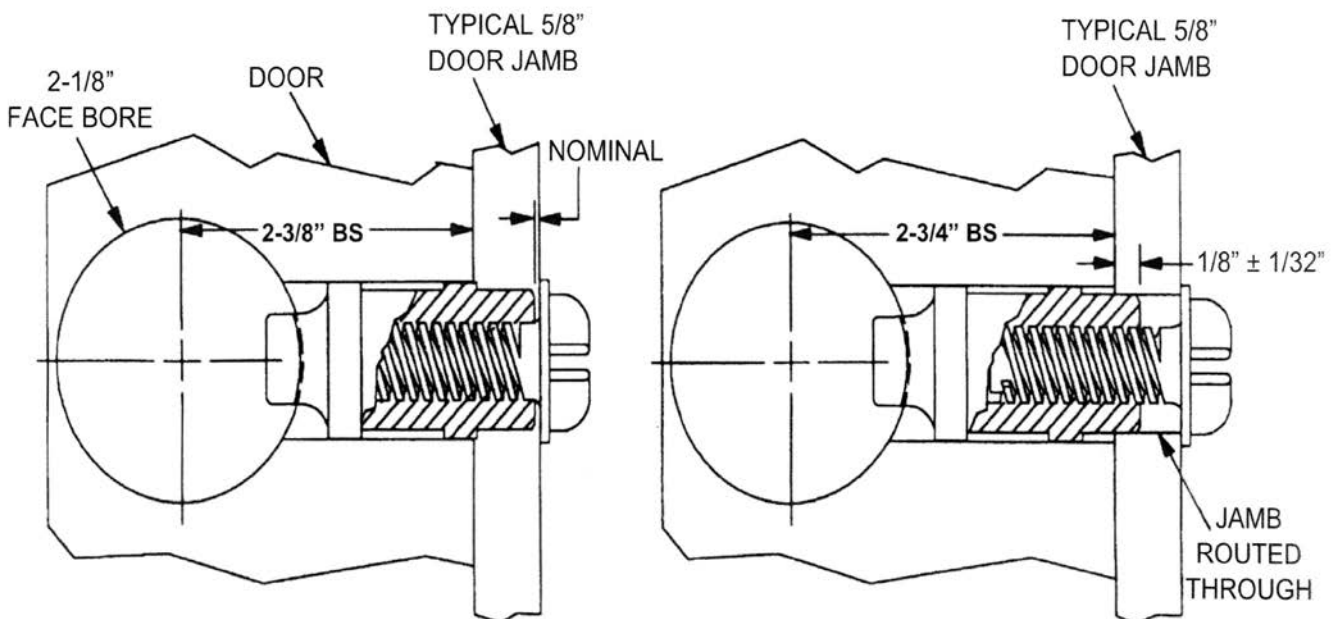

Chick's® STRAP (1PDP-S) Door Plug



- Use our Strap Door Plug when the jamb isn't routed all the way through.
- Installs quickly and easily in the shop and will telegraph any misalignment of strike prep and edge bore **before** the door unit leaves the shop.
- Strap Door Plug can remain assembled during door unit installation on the job site. Wraparound strap can be disassembled by cutting the strap with a utility knife.
- Saves time of predrilling hardwood or pre-finished jambs
- Saves money on costly call backs on damaged door complaints in the field or in the customers' warehouse.

*Made in
America!*

Installation Instructions

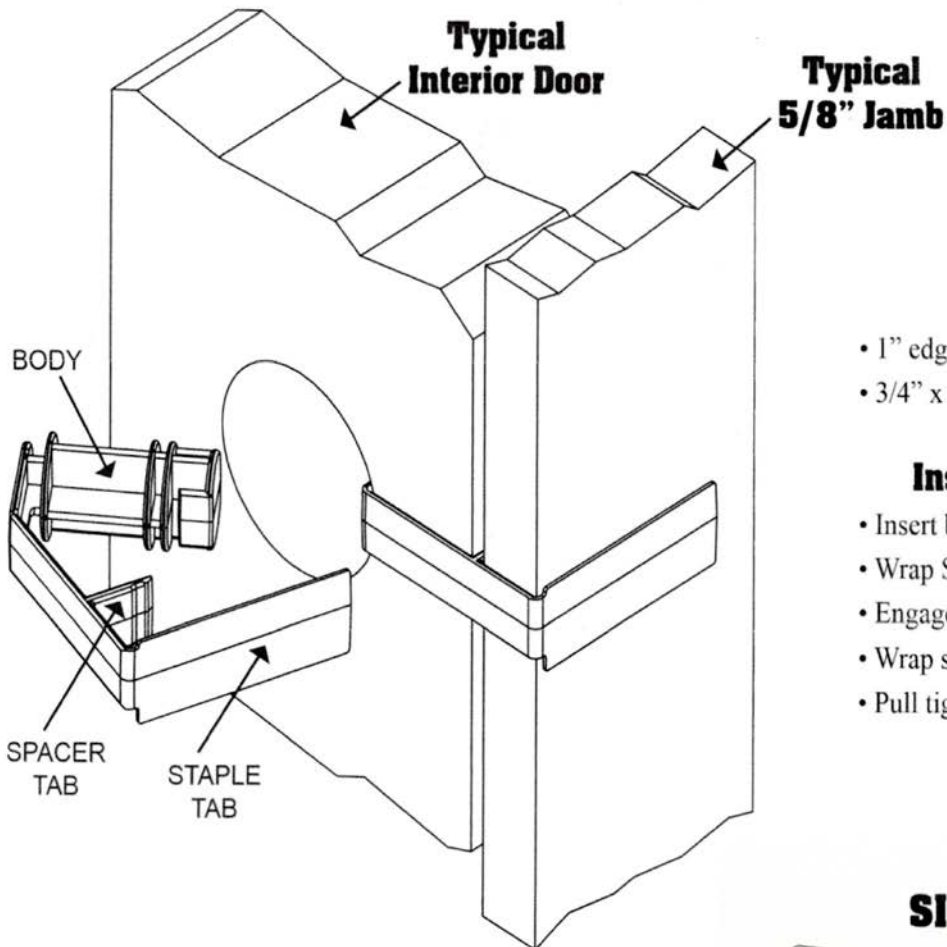

Requirements

- 1" edge bore
- 3/4" x 1" strike prep on jamb

Installation Instructions

- Insert body through face bore
- Wrap Strap over face of the door
- Engage spacer tab between door and jamb
- Wrap staple tab around back of jamb
- Pull tightly and staple tab to jamb

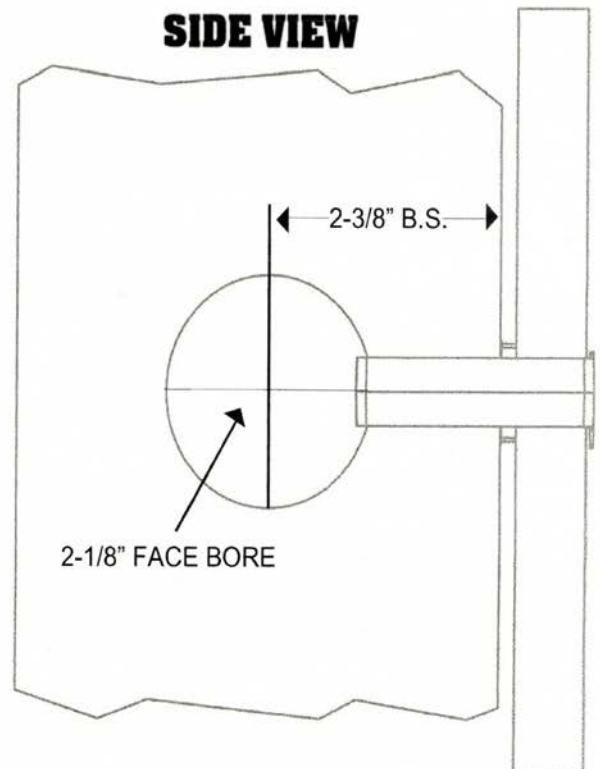
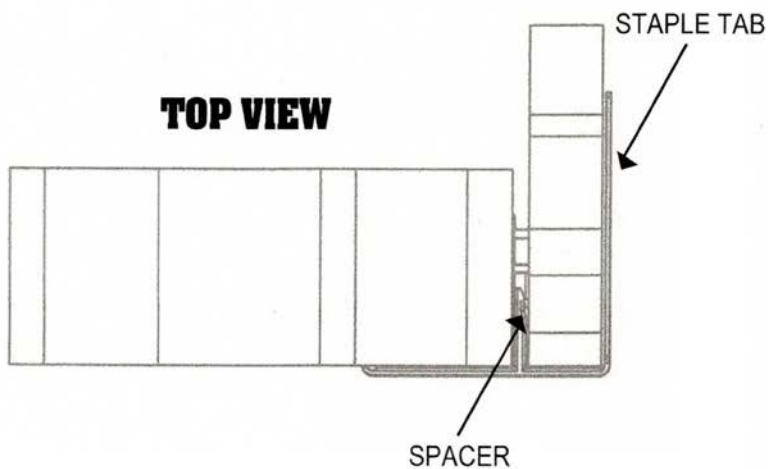

Chick's® STANDARD (SLDP-075) SIDELITE Door Plug



- Eliminates misalignment of strike prep and edge bore **before** the door unit leaves the shop.
- Installs in seconds and eliminates damaged doors and jambs during shipping.
- Can be used with either 2-3/8" or 2-3/4" backsets.
- Stronger key for heavier entry doors.
- Can be used as the temporary entry lock.

Machining Requirements:

- Edge bore must be 1" in diameter.
- Strike prep must be 3/4" x 1" x 5/8" deep minimum.

Installation Instructions:

1. Insert SideLite Plug into the door through the 1" edge bore so it's flush with the edge of the door stile. See **Figure 1**.
2. Close door into mullion. See **Figure 3**.
3. Slide SideLite Plug into strike prep. The keyslot must be visible. See **Figure 3**.
4. Insert compression key into the keyslot. See **Figure 4**.

*Made in
America!*

Installation Instructions

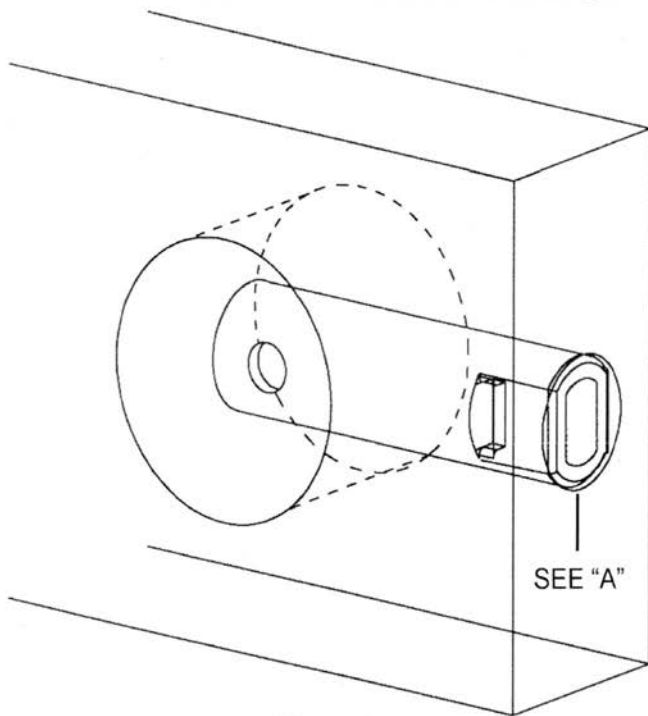

Figure 1
Typical 1-3/4" Exterior Door

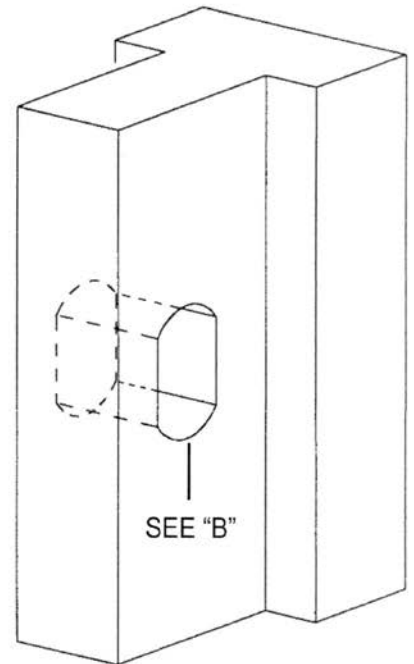

Figure 2
Typical SideLite Mullion or Astragal

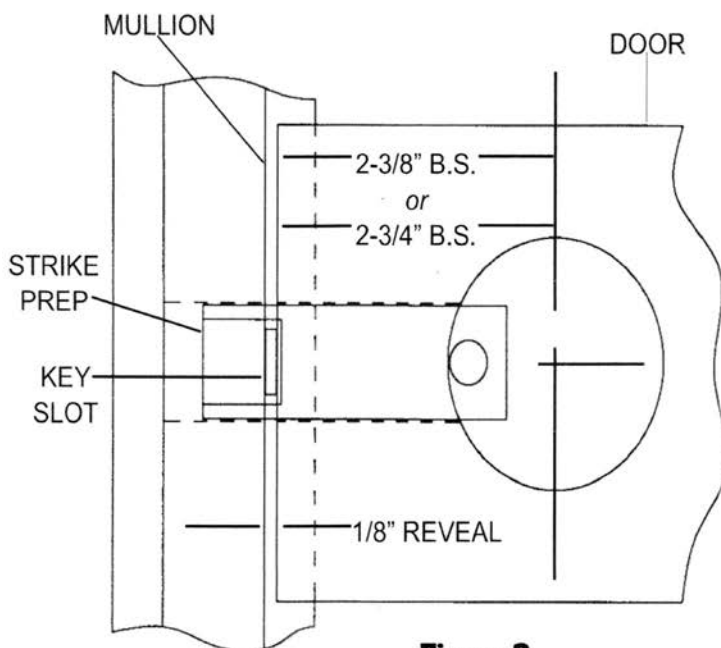

Figure 3
Front View

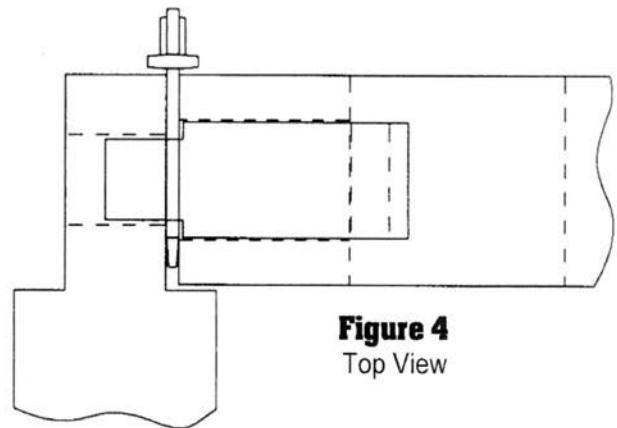

Figure 4
Top View

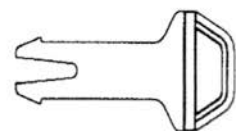

Figure 5
Compression Key

Chick's® STRIKE PLATE (SLDP-058) SIDELITE Door Plug



- Eliminates misalignment of strike prep and edge bore **before** the door unit leaves the shop.
- Installs in seconds and eliminates damaged doors and jambs during shipping.
- Can be used with either 2-3/8" or 2-3/4" backsets.
- Stronger key for heavier entry doors.
- Can be used as the temporary entry lock.

Machining Requirements:

- Edge bore must be 1" in diameter.
- Strike prep must be 3/4" x 1" x 5/8" deep minimum.
- Strike plate must have a minimum clearance opening of 3/4" x 1".

Installation Instructions:

1. Insert SideLite Plug into the door through the 1" edge bore so it's flush with the edge of the door stile. See **Figure 1**.
2. Close door into mullion. See **Figure 3**.
3. Slide SideLite Plug into strike prep. The keyslot must be visible. See **Figure 3**.
4. Insert compression key into the keyslot. See **Figure 4**.

*Made in
America!*

Installation Instructions

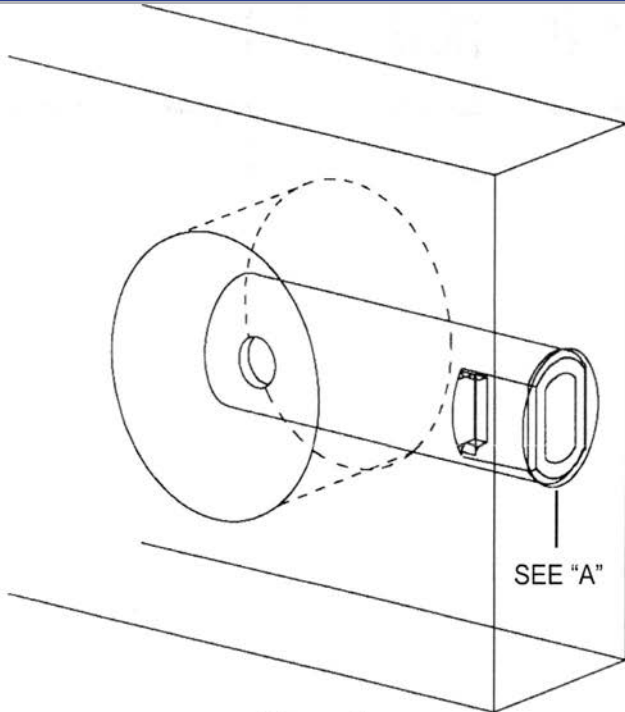

Figure 1
Typical 1-3/4" Exterior Door

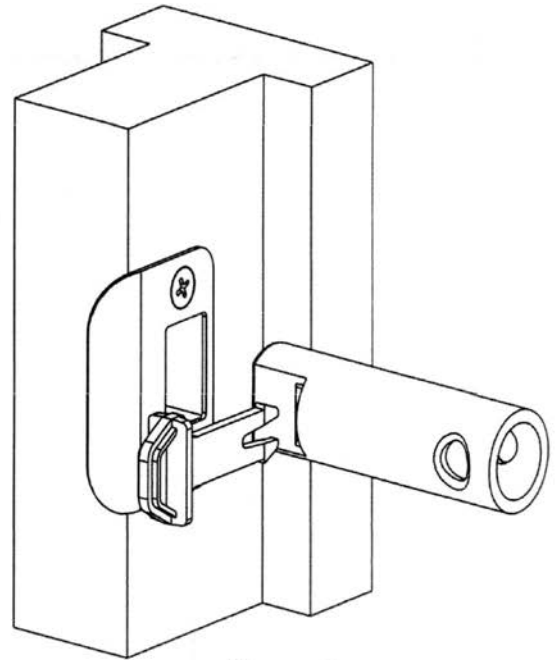

Figure 2
Typical Mullion or Astragal
With Strike Plate Applied

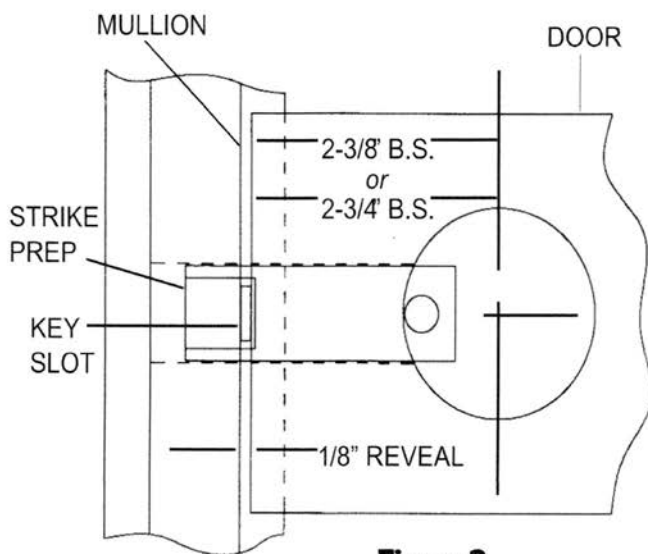

Figure 3
Front View

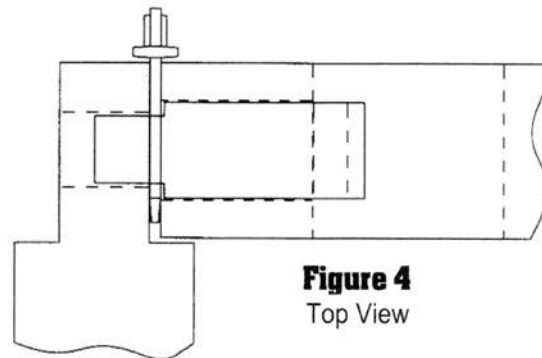

Figure 4
Top View

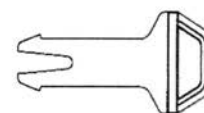

Figure 5
Compression Key

Chick's® UNIVERSAL BUSHING (UVB)



1. Determine which adjustable metal frame is to be used.
2. Apply the Bushing from the back side of the metal adjustable frame at the strike prep location.
3. Slide the Standard Door Plug (Item A) (female portion) from the edge bore in the door through the strike prep in the metal adjustable frame and into the bushing.
4. Install the bolt and washer (male portion) into the Standard Door Plug body and tighten securely.

*Made in
America!*

Installation Instructions

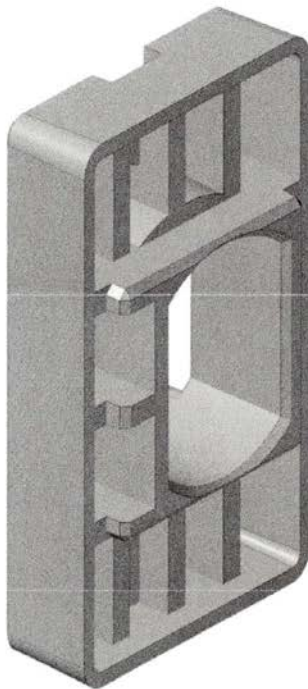

This side used with:
Span Rite



Item A

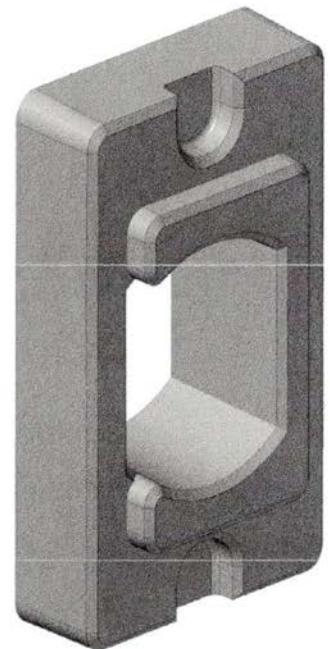

This side used with:
Redi Frame
Benchmark Stanley
Dunbarton
Timley
Fast-Frame

Chick's® LIFT HANDLE (LH)



- Chick's® Lift handles are manufactured with the same blend of material used in our Standard Door Plugs for added strength.
- Both pull and lift tests were conducted in our manufacturing plant and we are confident to claim that Chick's® Lift Handles are the strongest in the industry
- It is recommended to apply all eight screws; especially in the corners on heavier door units.

*Made in
America!*

Chick's®
CORNER
PROTECTORS
CP138 (1-3/8")
CP134 (1-3/4")

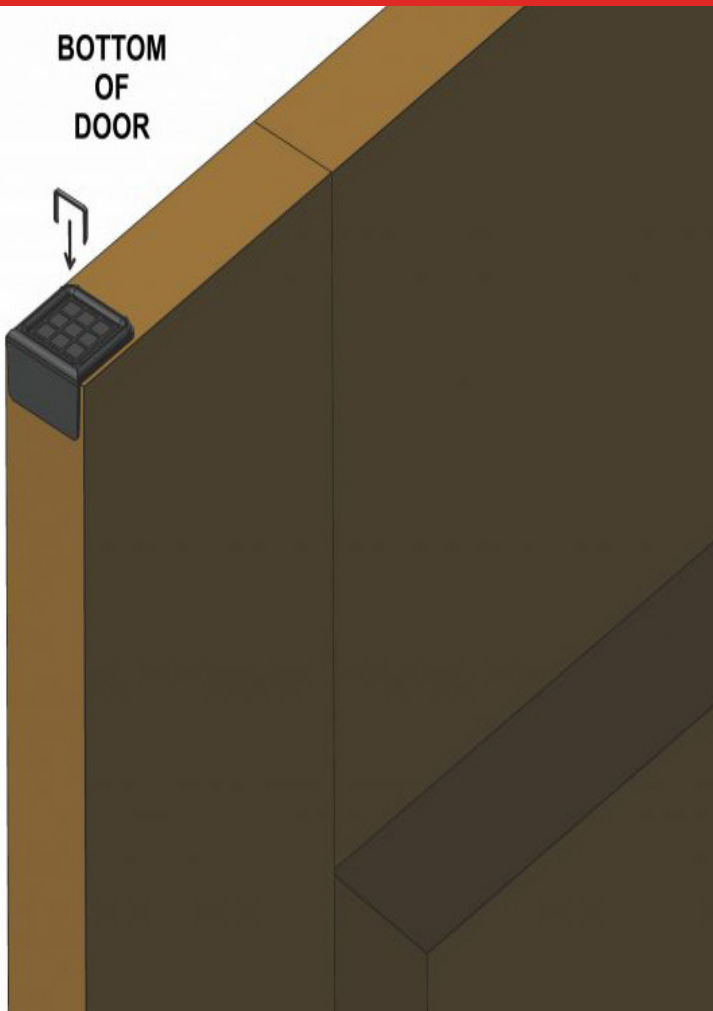

- Chick's® Corner Protectors are thicker than others available in the industry.
- They are available in two sizes, 1-3/8" and 1-3/4".
- They are designed with a built-in cushion which makes the corner protector easier to remove; including the staple!
- Our corner protectors are manufactured with the same material used in parts of our Standard Door Plugs for added strength.
- We are confident to claim that after extensive testing, Chick's® Corner Protectors will never crack or break while attached to the door.
- Protect the edges of your doors by simply stapling the corner protectors to the bottom two edges of the door. When ready to remove, simply pop off with a screwdriver.

*Made in
America!*

Chick's® CASING CLIP (1PCC)



- Our casing clip is the fastest and easiest way to secure the casing without the use of nails. (Also for door shops using the casing hoop system.)
- Holds casing securely in place for easy, damage-free transit.
- Easy for the builder to remove to install casing.
- No more puttying nail holes!
- Removable, reusable and recyclable!

*Made in
America!*

Chick's® DOOR CATCH (1PDC)



- Chick's® One Piece Door Catch is used by door installers and trades people on commercial jobsites.
- Simply insert the Door Catch into the edge bore.
- Temporary door hardware can be expensive. For just pennies, Chick's® Door Catch can prevent costly sheet rock repairs as well as damaged doors due to entry doors being blown open by the elements on the jobsite.
- The flexible spring-loaded head allows for the entry door to be opened and closed easily by trades people coming and going throughout the day on the jobsite.

*Made in
America!*

Chick's® HINGE PROTECTOR (1PHP)

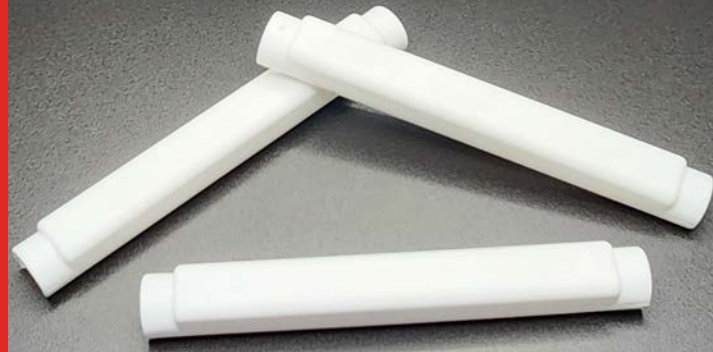

- Chick's® One-Piece Hinge Protectors are made with a specific blend of non-marring materials which help protect doors and hinges.
- The flat-top design feature creates improved door packing.
- If you are looking to reduce production time, our 4" hinge protector is slightly pliable making it easier and faster to install than traditional hinge protectors and rubber bands!

*Made in
America!*

Chick's® JAMB PROTECTOR (JP45)



- Chick's® jamb protector protects the bottom of the jamb from cracking or chipping during shipping and installation.
- Doors can easily be slid around the shop floor damage-free for faster packaging.
- Easily removed on the jobsite with pliers.
- Currently available in the 4-1/2" size.

*Made in
America!*

Chick's® BOLT HEAD BIT (BHB)

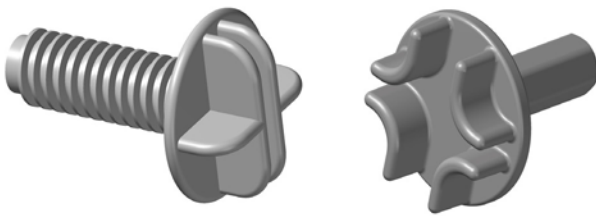

- Our Bolt Head Bit is used for faster installation of our Standard and Economy Door Plugs; cutting down on production time.
- Attach bolt head bit to a cordless drill.
- Set cordless drill at a reasonable speed and torque to assure tight and secure assembly. We recommend half speed setting.
- Attach bolt head to drill and simply screw bolt into door plug body.

*Made in
America!*

Product	Item Number	Description	Units Per Carton
	1PDP-A	Standard Door Plug, 2-3/8" Backset	1000
	1PDP-E	Economy Door Plug, 2-3/8" Backset	1000
	1PDP-S	Strap Door Plug, Not Routed Through Jamb	1000
	SLDP075	SideLite Door Plug, no Strike Plate Applied	1000 or 600
	SLDP058	SideLite Door Plug, W/Strike Plate Applied	1000
	LH	Heavy-Duty Lift Handle	100
	CP138	1-3/8" Corner Protector	5000
	CP134	1-3/4" Corner Protector	5000
	1PCC	Casing Clip	1000
	1PDC	Door Catch	2000
	1PHP	4" Hinge Protector	2500
	JP45	Jamb Protector / Skid Plate	3500
	UVB	Universal Bushing for Metal Frames	1000

Contact

chick@chicksdoorplugs.com

800.666.7305

503.657.7300 - fax

503.201.7546 - cell

**PLACE
YOUR
ORDER
TODAY!**

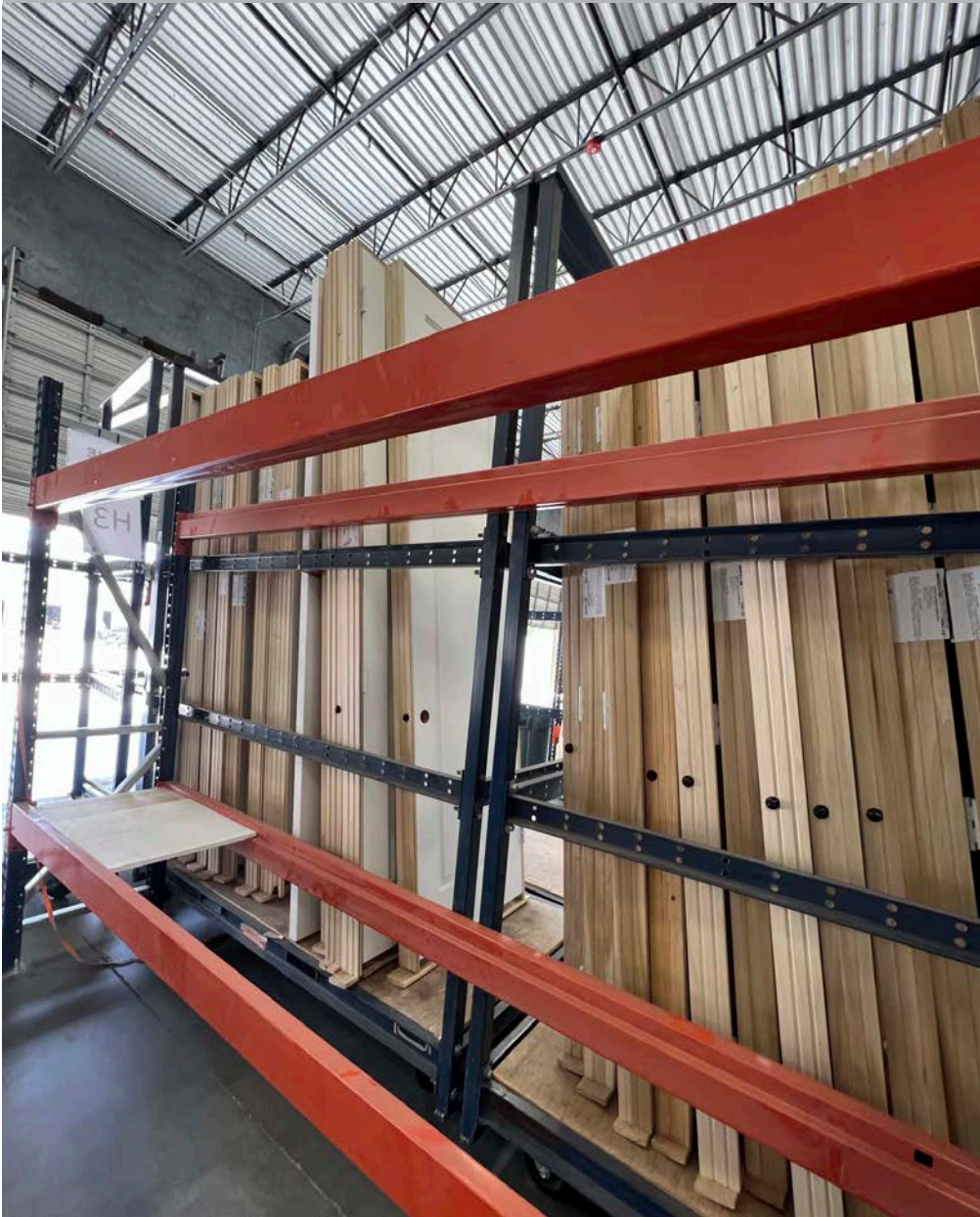

Ideal Door Components, Inc.

Proudly Supplied By



615-885-0355 | www.warrenbros.com